

- S1210 - 1.21x1.21 m
- S1700 - 1.70x1.70 m

Torre/Reazioni – Masts/Reactions – Mat/Réactions – Maste/Eckdrücke – Måstil/Reacciones – Tramo/Reacções

S1210

 15 m \rightarrow 47.5 m

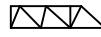
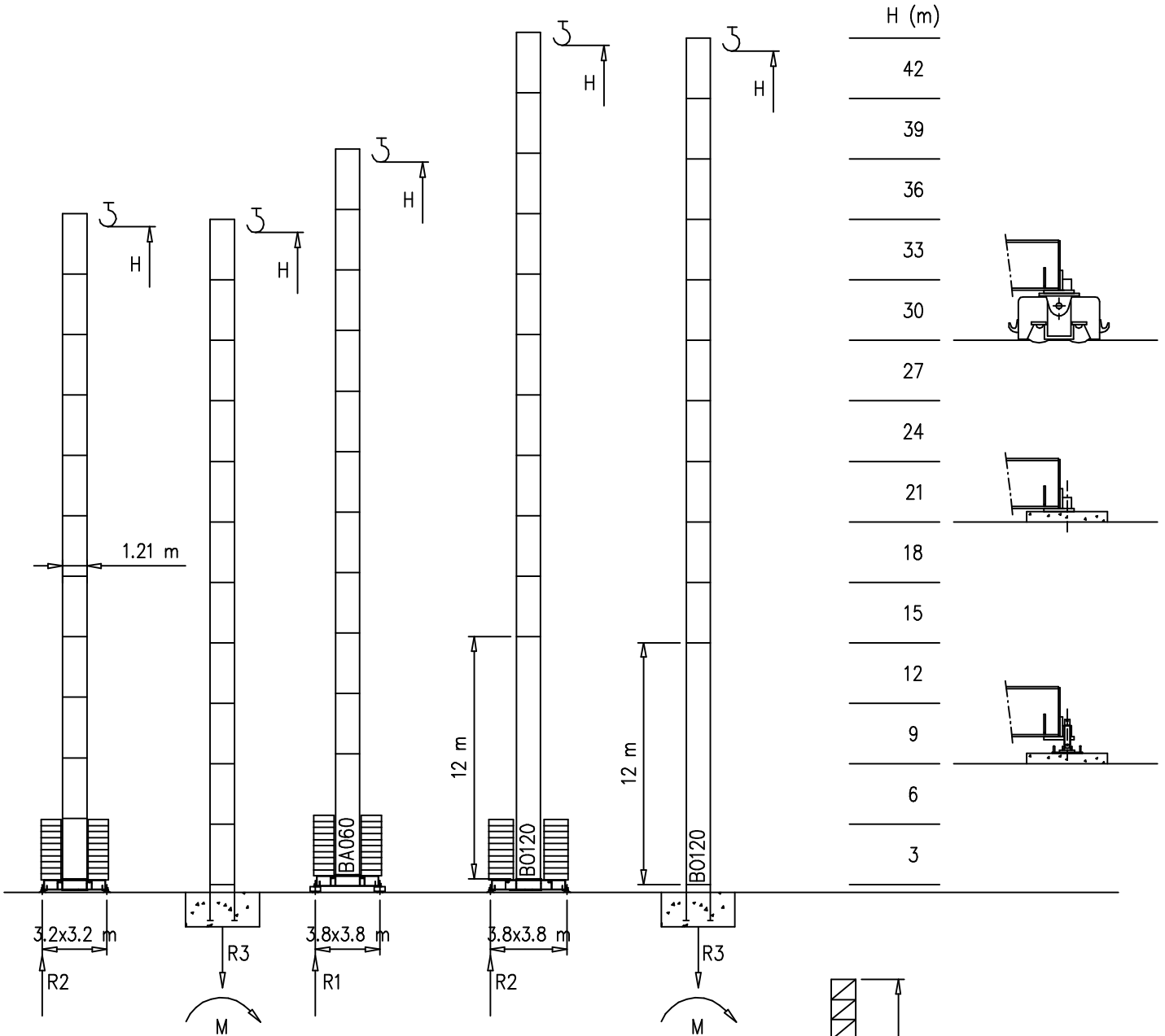

H=37-42 m		H=24-36 m		H=0-23 m	
R1		R1	53 t	R1	49 t
R2	69 t	R2	53 t	R2	47 t
R3	40 t	R3	25.6 t	R3	22 t
M	185 tm	M	116 tm	M	80 tm

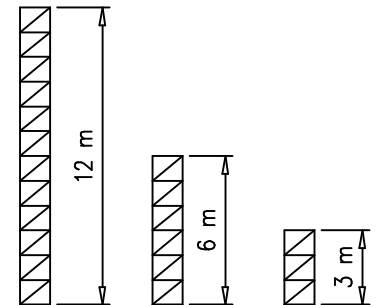

Peso zavorra – Ballast weight – Poids du lest – Ballastgewicht – Peso de lastre

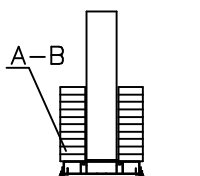

H	n°	Tot.
0-18 m	12 A-B	36000 kg
19-36 m	18 A-B	54000 kg
37-42 m	24 B	72000 kg

	A	B
L	3.6m	4.0m
k	0.3m	1.2m
d	1.15m	0.19m

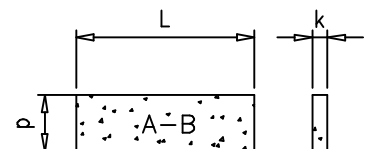

Torre/Reazioni – Masts/Reactions – Mat/Réactions – Maste/Eckdrücke – Mästil/Reacciones – Tramo/Reacções

S1700

15 m → 47.5 m

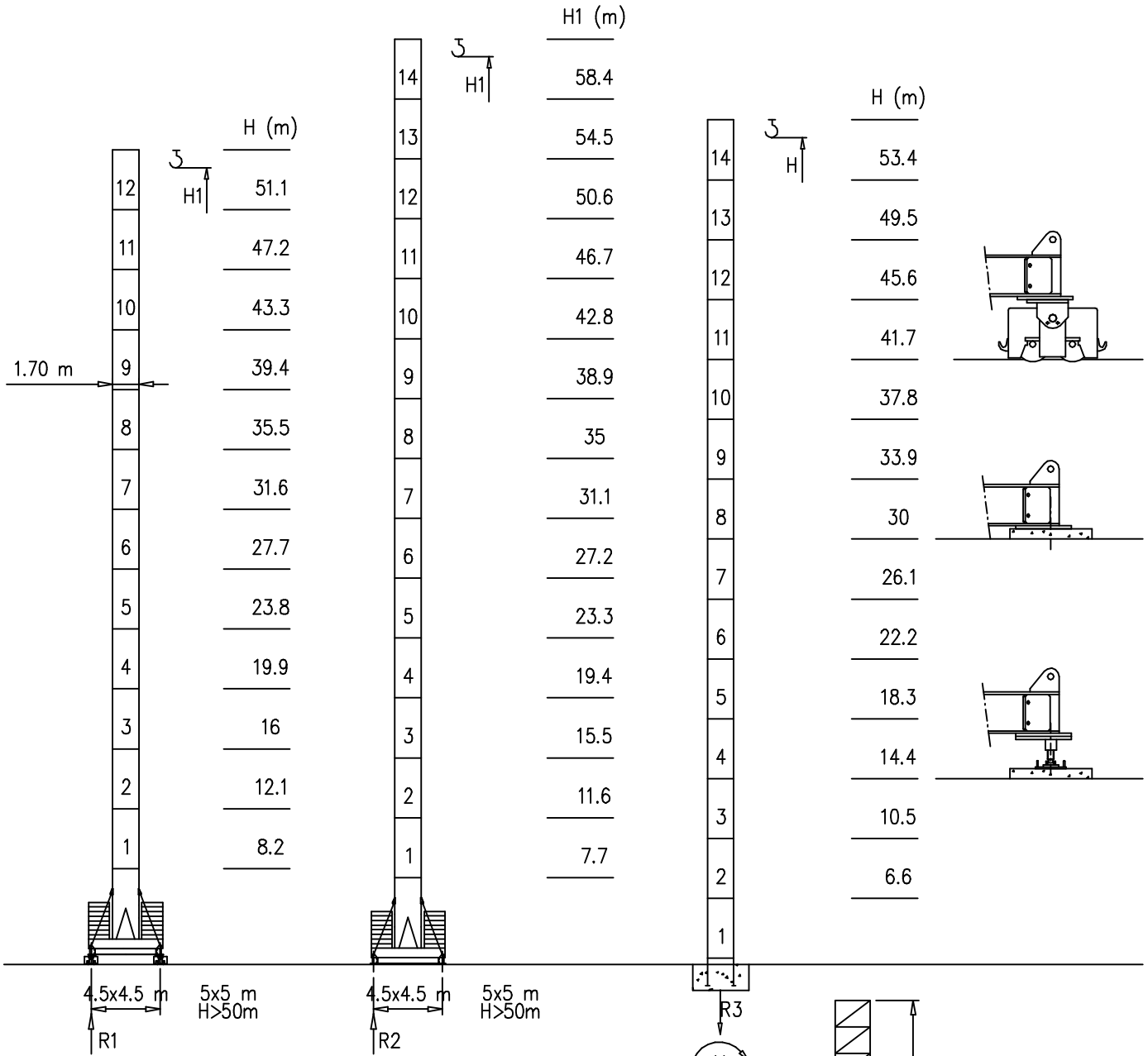

H=46–58 m		H=36–45 m		H=0–35 m	
R1	106 t	R1	72 t	R1	65 t
R2	106 t	R2	72 t	R2	65 t
R3	95 t	R3	61 t	R3	54 t
M	336 tm	M	194 tm	M	156 tm

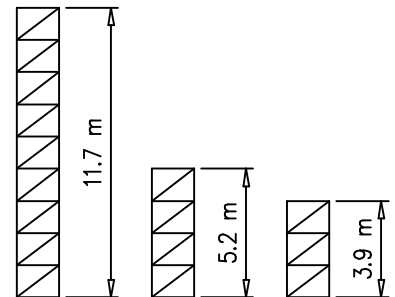



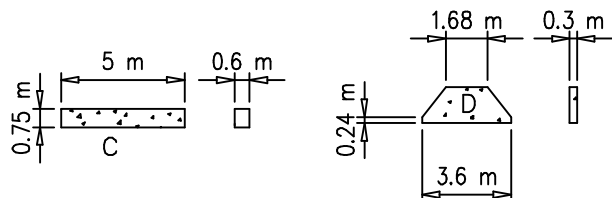
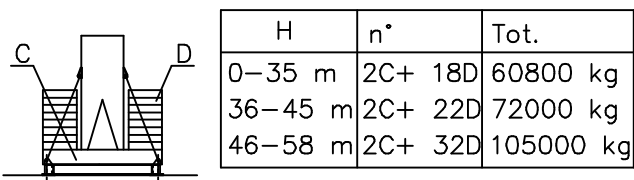





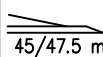

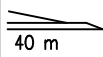

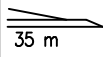
Peso zavorra – Ballast weight – Poids du lest – Ballastgewicht – Peso de lastre

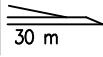

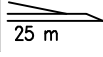

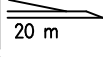

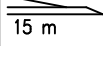





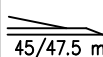

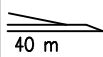
Curve di carico – Courbes de charges – Load diagrams – LastKurven – Curvas de cargas

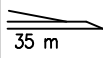
Pmax 2500 kg

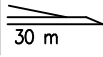
	12000 kg		2	28.5	30	32.5	35	37.5	40	42.5	45	m	47.5	m
		45/47.5 m	2500	2500	2360	2120	1900	1720	1560	1420	1300	kg	1000	kg
	10800 kg		2	27.5	30	32.5	35	37.5	40	m				
		40 m	2500	2500	2400	2160	1940	1760	1600	kg				
	10800 kg		2	30			32.5	35	m					
		35 m	2500	2500			2320	2200	kg					
	9600 kg		2	30			m							
		30 m	2500	2500			kg							
	8400 kg		2	25		m								
		25 m	2500	2500		kg								
	7200 kg		2	20		m								
		20 m	2500	2500		kg								
	4800 kg		2	15		m								
		15 m	2500	2500		kg								

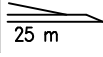

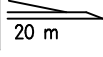

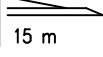





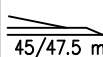

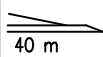

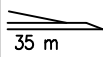
Pmax 3000 kg

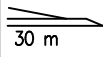
	12000 kg		2	24.5	27.5	30	32.5	35	37.5	40	42.5	45	m	47.5	m
		45/47.5 m	3000	3000	2650	2360	2120	1900	1720	1560	1420	1300	kg	1000	kg
	10800 kg		2	25	27.5	30	32.5	35	37.5	40	m				
		40 m	3000	3000	2690	2400	2160	1940	1760	1600	kg				
	10800 kg		2	28.5	30	32.5	35	m							
		35 m	3000	3000	2500	2320	2200	kg							
	9600 kg		2	29	30	m									
		30 m	3000	3000	2800	kg									
	8400 kg		2	25		m									
		25 m	3000	3000		kg									
	7200 kg		2	20		m									
		20 m	3000	3000		kg									
	4800 kg		2	15		m									
		15 m	3000	3000		kg									

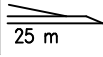

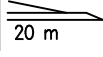
Pmax 4000/2000 kg

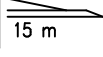
	12000 kg		2	19.5	22.5	25	27.5	30	32.5	35	37.5	40	42.5	45	m	47.5	m
		45/47.5 m	4000	4000	3370	2970	2650	2360	2120	1900	1720	1560	1420	1300	kg	1000	kg
	10800 kg		2	20	22.5	25	27.5	30	32.5	35	37.5	40	m				
		40 m	4000	4000	3520	3100	2690	2400	2160	1940	1760	1600	kg				
	10800 kg		2	22.5	25	27.5	30	32.5	35	m							
		35 m	4000	4000	3560	3180	2870	2320	2200	kg							
	9600 kg		2	23	25	27.5	30	m									
		30 m	4000	4000	3730	3360	2800	kg									
	8400 kg		2	24	25	m											
		25 m	4000	4000	3900	kg											
	7200 kg		2	20		m											
		20 m	4000	4000		kg											
	4800 kg		2	15		m											
		15 m	4000	4000		kg											



Montaggio – Montage – Erection – Montage – Montaje – Montagem

X (m)	kg
3,2x3,2	2300kg
3,8x3,8	4500kg
4,5x4,5	3800kg

S1210	
(m)	(kg)
3	610
6	1500
12	2500

S1700	
(m)	(kg)
3,9	1600
5,2	2100
11,7	4200

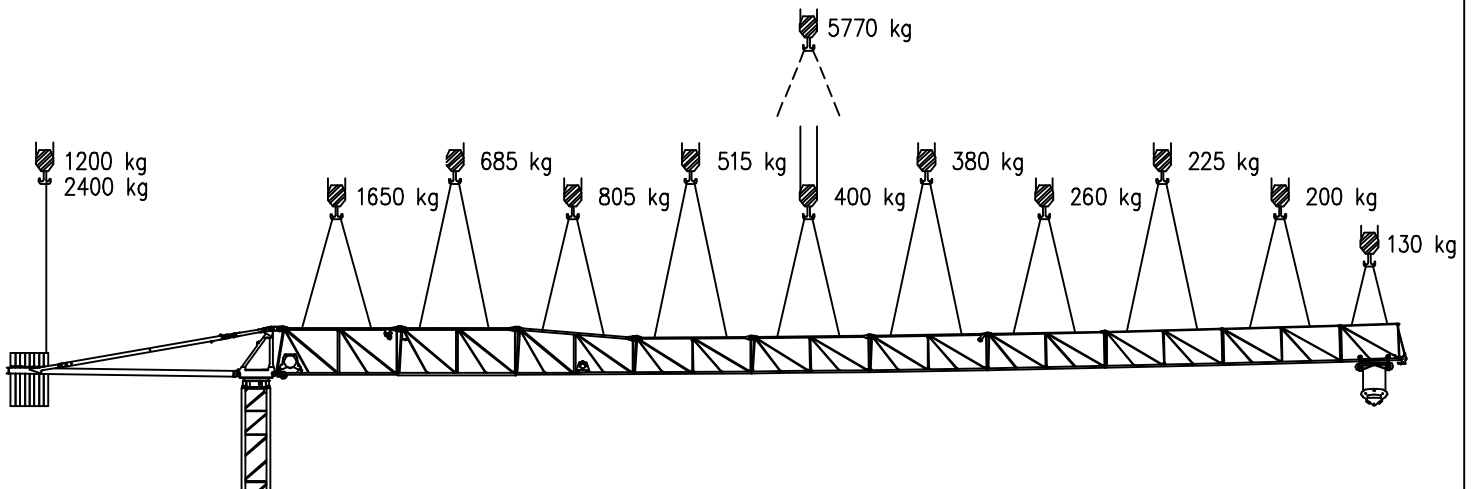
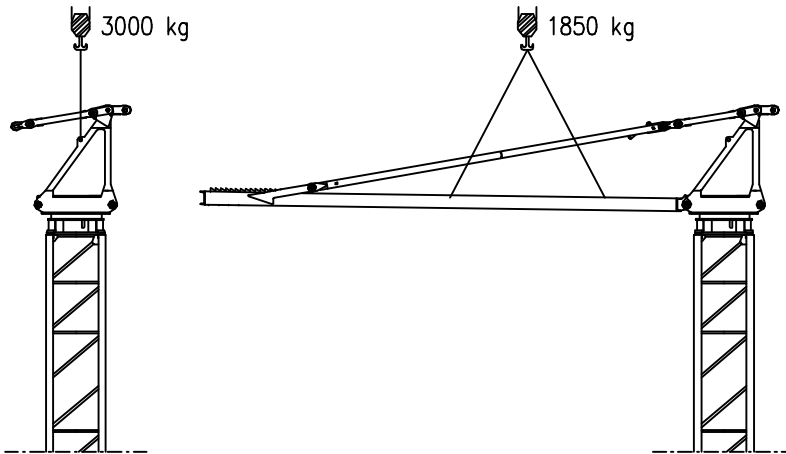
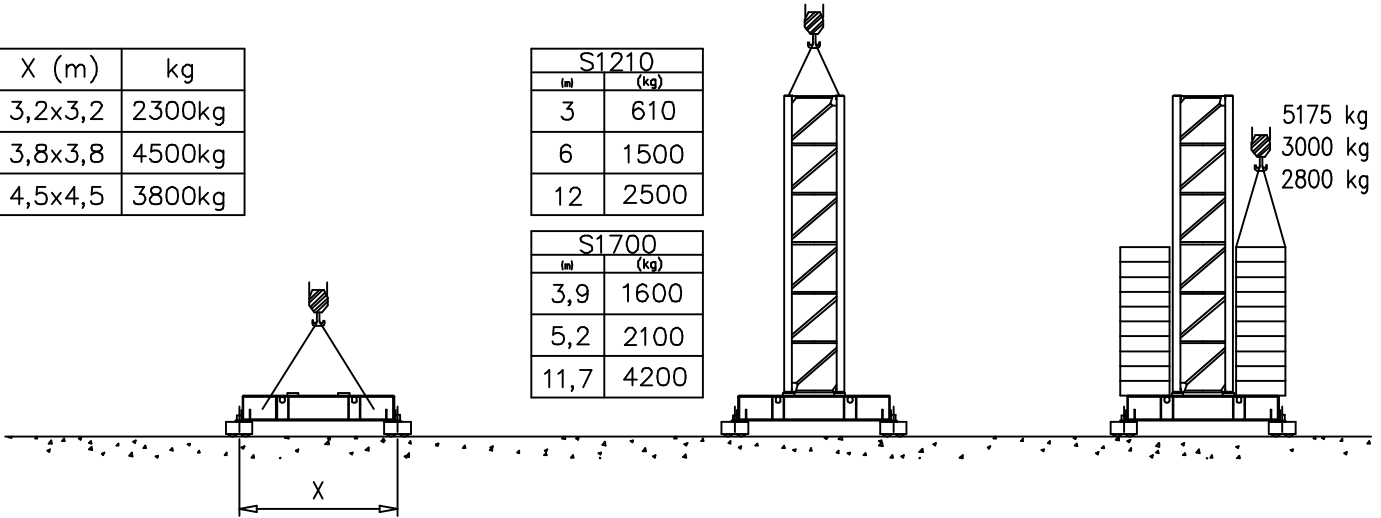

Meccanismi – Mechanisms – Mécanismes – Antriebe – Mecanismos

Sollevamento S15.40 e V15.40 Hoisting Levage Heben Elevaciòn Elevaçao			1a	4 m/min	2500 kg	11 kW	S15.40	
2a			20 m/min	2500 kg	V15.40			
			3a	40 m/min	1200 kg		20 kVA	
Sollevamento S20.60 e V20.60 Hoisting Levage Heben Elevaciòn Elevaçao			1a	7 m/min	2500 kg	14.7 kW	S20.60	
			2a	28 m/min	2500 kg		28 kVA	
			3a	56 m/min	1200 kg		V20.60 24 kVA	
Sollevamento S20.40 e V20.40 Hoisting Levage Heben Elevaciòn Elevaçao			1a	4 m/min	3000 kg	14.7 kW	S20.40	
			2a	20 m/min	3000 kg		28 kVA	
			3a	40 m/min	1500 kg		V20.40 24 kVA	
Sollevamento S25.60 e V25.60 Hoisting Levage Heben Elevaciòn Elevaçao			1a	7 m/min	3000 kg	18.5 kW	S25.60	
			2a	28 m/min	3000 kg		34 kVA	
			3a	56 m/min	1500 kg		V25.60 28 kVA	
Sollevamento S15.40 e V15.40 Hoisting Levage Heben Elevaciòn Elevaçao			1a	4 m/min	2000 kg	11 kW	S15.40	
			2a	20 m/min	2000 kg			22 kVA
			3a	40 m/min	1200 kg			
			1a	2 m/min	4000 kg		V15.40	
			2a	10 m/min	4000 kg			20 kVA
			3a	20 m/min	2400 kg			
Sollevamento S20.60 e V20.60 Hoisting Levage Heben Elevaciòn Elevaçao			1a	7 m/min	2000 kg	14.7 kW	S20.60	
			2a	28 m/min	2000 kg			28 kVA
			3a	56 m/min	1200 kg			
			1a	3.5 m/min	4000 kg		V20.60	
			2a	14 m/min	4000 kg			24 kVA
			3a	28 m/min	2400 kg			
Carrello Trolleying Distribution Katzfahren Distribuciòn Distribuiçao			1a	5 m/min	4000 kg	2.2 kW	Potenza elettrica necessaria Puissance électrique nécessaire Necessary electric power Anschlusswert – Potencia	
			2a	25 m/min	4000 kg			
			3a	50 m/min	2000 kg			
Rotazione Slewing Orientation Schwenken Orientaciòn Rotaçao			1a	0 → 0.2	giri/min tr/min rp/min	2.2 kW @ 1200rpm		
			2a	0 → 0.6				
			3a	0 → 0.9				
Traslazione Travelling Translation Kranfahren Traslaciòn Translaçao			1a	0 → 10	m/min	3.7 kW		
			2a	0 → 20				

Rete elettrica – Réseau – Mains supply – Netzstrom – Red – Rede electrica 400V – 50 Hz

AFM Gru FMgru s.r.l.
via Emilia 11-29010 Pontenure PC ITALY
tel. 0523/510446 ric.aut. fax 0523/510365
www.fmgru.com e-mail: info@fmgru.com

FEM 1.001
2000/14/CE



Documento commerciale non contrattuale
Per tutte le informazioni tecniche riferirsi
alle corrispondenti istruzioni

Unverbindliches Vertriebsdokument.
Für technische Informationen, siehe die
entsprechenden Anweisungen.

This commercial document is not legally
binding. For any technical information, please
refer to the corresponding instructions.

Documento comercial non contractual
Para cualquier información técnica,
ver la noticia correspondiente.

Code: 15ICA37T25A0
Ed. Data Rev. Data
1 15.04.04 1 12.04.05